

Pulse mode operation of Love wave devices for biosensing applications

M. I. Newton,^{*a} G. McHale,^a F. Martin,^a E. Gizeli^a and K. A. Melzak^b

^a Department of Chemistry and Physics, The Nottingham Trent University, Clifton Lane, Nottingham NG11 8NS, UK. E-mail: michael.newton@ntu.ac.uk

^b Institute of Biotechnology, University of Cambridge, Tennis Court Road, Cambridge, Cambridgeshire CB2 1QT, UK

Received 10th October 2001, Accepted 6th November 2001

First published as an Advance Article on the web 16th November 2001

In this work we present a novel pulse mode Love wave biosensor that monitors both changes in amplitude and phase. A series of concentrations of 3350 molecular weight poly(ethylene glycol) (PEG) solutions are used as a calibration sequence for the pulse mode system using a network analyzer and high frequency oscilloscope. The operation of the pulse mode system is then compared to the continuous wave network analyzer by showing a sequence of deposition and removal of a model mass layer of palmitoyl-oleoyl-sn-glycerophosphocholine (POPC) vesicles. This experimental apparatus has the potential for making many hundreds of measurements a minute and so allowing the dynamics of fast interactions to be observed.

Introduction

A Love wave is produced in a surface skimming bulk wave (SSBW) device when an insulating overlayer with an acoustic shear velocity less than that in the bulk is deposited over the propagation path.¹ The overlayer has the effect of confining energy to the surface and hence acting as a guiding layer. The use of Love wave devices for biosensing applications was first reported in 1992² and has since attracted much attention.³⁻⁷ The surface mass sensitivity of acoustic wave devices is known to increase with frequency.³ However, for liquid sensing applications only a thin layer of fluid, called the penetration depth, above the sensor is probed.⁴ This penetration depth, δ , reduces as the frequency increases according to $\delta = (2\eta/\rho\omega)^{0.5}$ where ω is the angular frequency, η is the viscosity and ρ the density of the fluid. When biological materials, such as a vesicle layer, are deposited, they may initially be attached to the mass sensitive surface as a series of spheres that then can be opened out to form a monolayer or bilayer. The biological mass layer within the penetration depth thus changes and an acoustic signal response in both amplitude and phase is observed. The physical interpretation of the response is not straight forward in the sense of the Sauerbrey equation giving simply a measure of mass, but will include changes in the viscosity–density product and effects from changes in the dielectric constant and surface charge density. The traditional technique used for biosensing experiments with Love wave devices, which have been reported extensively in the literature, is the continuous wave based network analyzer. Whilst the network analyzers measure the single transit signal across the device, they contain unwanted signals in the form of edge reflection and triple transit signals from the interdigital transducers used for generating and detecting the acoustic wave. By operating in pulse mode, we can calculate the time of flight of the acoustic mode of interest and measure only that signal with all other signals being rejected. A biosensing system utilizing the measurement of power in pulsed SH-SAW (shear horizontal surface acoustic wave) devices has recently been reported⁸ demonstrating the feasibility of working

in pulsed mode. In our work we present a measurement system that gives both the amplitude and phase of a pulsed signal and, using an analogue averaging system, will allow many hundreds of measurements to be made per minute

Experimental

The Love wave devices used in this work were of a split-finger (double-double) interdigital transducer (IDT) design which, for Rayleigh wave devices, is known to resonate with equal strength at both the fundamental frequency and third harmonic. Devices were fabricated on ST-cut quartz with propagation orthogonal to the crystalline x direction, which is known to support a SSBW, and designed for a fundamental frequency on an uncoated device of 110 MHz. Each IDT was of length 40λ and aperture 65λ where the wavelength $\lambda = 45\mu\text{m}$; finger widths were $6.75\mu\text{m}$ and spacings were $4.5\mu\text{m}$. The path length was 7 mm and the guiding layer consisted of a $1\mu\text{m}$ layer of Shipley S1813 photoresist; after deposition the films were cross linked by baking in an oven at $200\text{ }^\circ\text{C}$ for 2 h. Prior to the biosensing experiment, these layers were made hydrophilic by treatment with a sol-gel derived silica coating. A solution consisting of 1 ml of 5.8 M HCl mixed with 5 drops of orthosilicate (Aldrich) was prepared. The devices were spin coated with 5 drops of pure orthosilicate and then 5 drops of the HCl–orthosilicate mixture, each layer at 4000 rpm and for a duration of 35 s; the layer was finally washed with deionised water. A flow cell configuration was used for the biosensing experiments. A silicone gasket was used to isolate the SAW path from the IDTs and liquid was passed through the flow cell at a rate of 5 ml min^{-1} for the calibration experiment and 0.5 ml min^{-1} for the biosensing.

A schematic diagram of the pulse mode system is shown in Fig. 1. A continuous radio frequency (RF) signal from a Marconi 2022D signal generator was divided using a M/A-Com T-1000 power-splitter and one output of the splitter was combined with a pulse from a Thurlby TG105 pulse generator using two double balanced mixers (Mini-Circuits ZFM-4) to produce the pulsed RF signal. This signal was amplified using a M/A-Com AMC182 (28 dB) amplifier before being applied to the generating IDT of the Love wave device. The signal from the detection IDT of the device were fed through two cascaded AMC182 giving a total gain of around 56 dB. This signal was power-split using a T-1000 and one output fed to a diode detector (Agilent HP8471D) then into one of the two SR250 gated integrator and boxcar averagers (Stanford Research Systems); this signal represented the amplitude measurement of the pulse. The phase measurements utilized the other signals from the T-1000 power-splitters. The output from the first power-splitter was a continuous wave signal at 108 MHz; the other power-splitter gave the pulsed output from the Love wave device. These were fed into a third double balanced mixer

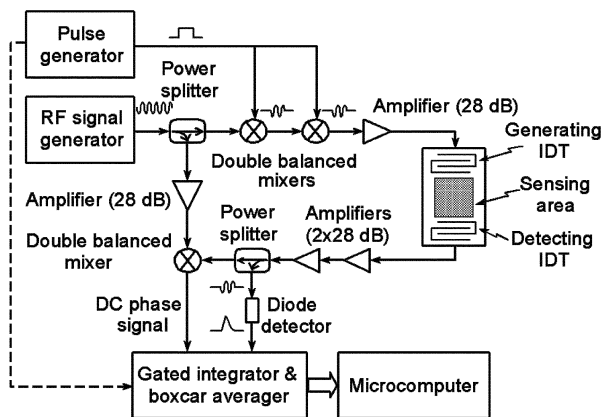

Fig. 1 Schematic diagram of the pulse mode system.

(Mini-Circuits ZFM-4) operating in the phase detection mode producing a dc output which, for the duration of the pulse, was proportional to the phase difference between the two signals; this output was fed to a second SR250. The pulse mode system in Fig. 1 is to provide a proof-of-principle of the pulse mode method and so uses discrete components. However, the same method could be implemented by integrating many of these components (signal sources, amplifiers, mixers, etc.) onto a single chip and so provide the basis for a working sensor.

Gated integrators and boxcar averagers are devices designed to recover fast, repetitive analog signals. A time 'gate' is generated a set delay from an external trigger (also provided by the TG105) and of a predetermined width. The gated integrator amplifies and integrates the signal that is present during the time the gate is open, ignoring noise and interference that may be present at other times. The boxcar averaging means that the output of the gated integrator is continuously averaged over many shots of the experiment. Since any signal present during the gate will add linearly, while noise will add in a random walk fashion as the square root of the number of shots, averaging N shots will improve the signal-to-noise ratio by a factor of N (in these experiments we used $N = 100$). The gate of each SR250 was set to coincide with the peak of the detected signal pulse so measuring only the peak amplitude and value of phase only for the duration of the pulse. The pulse mode system produced 1.5 μs pulses of 108 MHz signal with a repetition rate of 1 kHz. A continuous wave comparison experiment used the same device and flow cell arrangement connected to a Hewlett-Packard 4195A network analyzer. Data collection rates were 1.7 s per measurement for the network analyzer and 0.7 s per measurement for the pulse mode system.

Results and discussion

To provide a simple calibration for the pulse mode system an experiment was devised using different concentrations of 3350 molecular weight poly(ethylene glycol) (PEG) in the following sequence (in g l^{-1}); 34.4, 68.8, 103.2, 137.6, 172.0, 206.0, 240.8 and 275.2. This sequence was shown many times to produce repeatable changes in amplitude and phase for both the pulse and continuous wave systems. Fig. 2 shows the network analyzer amplitude and phase measurements for this sequence whilst Fig. 3 shows the same sequence for the pulsed amplitude and phase. A LeCroy 9362C 1.5GHz bandwidth oscilloscope and a set of calibrated attenuators were used to verify the magnitude of the changes in amplitude and phase for the pulse mode system; the data shows that the pulse and CW systems give the same results for amplitude to within 5%. This would appear at first sight to contradict the data of Stevenson *et al.*⁸

which give significant differences between the detected power for the pulse and CW systems. However, in our system the measurement of amplitude results from sitting the gate on the peak of the signal rather than making a power measurement of the entire pulse. Prior to any subsequent experiments, a PEG sequence was passed through the flow cell and the data used to convert the measured voltages from the pulse system into amplitude in dB and phase angle in degrees.

Fig. 4 shows the change in insertion loss and phase as a function of time for a model biosensing experiment measured with the network analyzer. This experimental sequence was also used for the pulsed experiments for which the data is shown in Fig. 5. The sequence consisted of initially a buffer solution, phosphate buffered saline (PBS), which was then followed by deposition of 0.2 mg ml^{-1} of vesicles of palmitoyl-oleoyl-sn-glycerophosphocholine (POPC) in PBS. The vesicle layer was then removed by a detergent, *tert*-octyl-phenoxyethoxyethanol (Triton) at 0.1 (w/v) % in PBS followed by a second sequence of POPC deposition and removal. The greater attenuation obtained during the first POPC deposition is consistent with previously published work.⁹⁻¹⁰

The data presented here clearly demonstrates the ability of the pulse system to provide accurate measurements of amplitude and phase for this type of experiment. The data collection rate that has been used in these pulse experiments is 86 measurements per minute which has been determined by the GPIB configuration used. The gated integrator and boxcar averager is an analogue device, which means that it produces a continuously variable output. The use of a faster analogue to digital converter would allow many hundreds of measurements to be made each minute allowing rapid reactions to be observed.

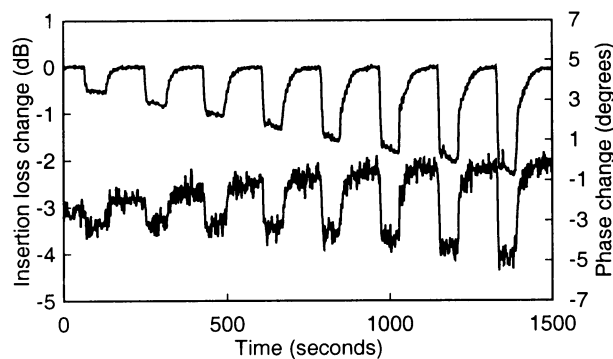

Fig. 2 Change in insertion loss (upper line) and phase (lower line) for a sequence different concentrations of 3350 molecular weight poly(ethylene glycol) solutions using the continuous wave system.

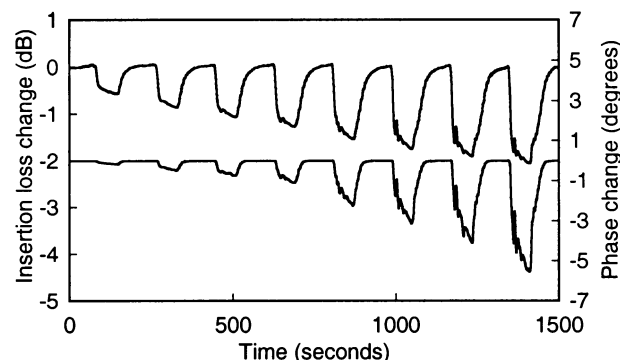

Fig. 3 Change in insertion loss (upper line) and phase (lower line) for a sequence different concentrations of 3350 molecular weight poly(ethylene glycol) solutions using the pulse mode system.

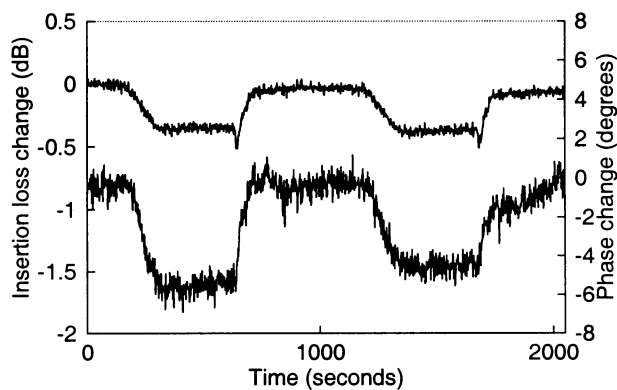

Fig. 4 Change in insertion loss (upper line) and phase (lower line) as a function of time for two cycles of POPC deposition and removal using the continuous wave system.

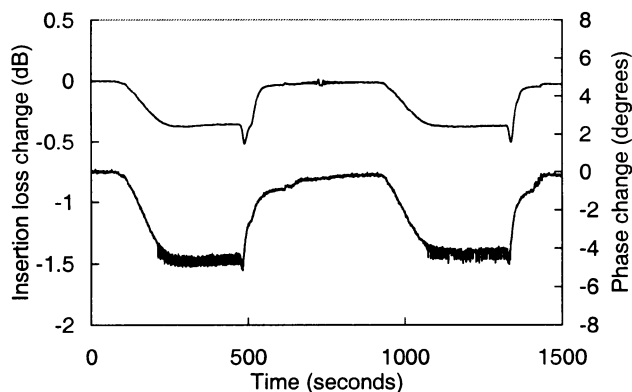

Fig. 5 Change in insertion loss (upper line) and phase (lower line) as a function of time for two cycles of POPC deposition and removal using the pulse mode system.

Acknowledgement

The authors gratefully acknowledge the financial support of BBSRC provided by research grant 301/E11140. The authors would also like to thank Dr. V. W. Rampton for helpful discussions.

References

- 1 Y. V. Gulyaev, *IEEE Trans. Ultrason., Ferroelectr., Freq. Control*, 1998, **45**, 935.
- 2 E. Gizeli, A. C. Stevenson, N. J. Goddard and C. R. Lowe, *IEEE Trans. Ultrason., Ferroelectr., Freq. Control*, 1992, **39**, 657.
- 3 F. Hermann, D. Hahn and S. Buttgenbach, *Appl. Phys. Lett.*, 1999, **74**, 3410.
- 4 B. Jacoby and M. J. Vellekoop, *Sens. Actuators, A*, 1998, **68**, 275.
- 5 M. Weiss, W. Welsch, M. v. Schickfus and S. Hunklinger, *Anal. Chem.*, 1998, **70**, 2881.
- 6 B. Jacoby and M. J. Ellekoop, *IEEE Trans. Ultrason., Ferroelectr., Freq. Control*, 1998, **45**, 1293.
- 7 L. G. Harding and J. Du, *Smart Mater. Struct.*, 1997, **6**, 716.
- 8 A. C. Stevenson, H. M. Mehta, R. S. Sethi, L-E. Cheran, M. Thompson, I. Davies and C. R. Lowe, *Analyst*, 2001, **126**, 1619.
- 9 E. Gizeli, C. R. Lowe, M. Liley and H. Vogel, *Sens. Actuators, B*, 1996, **34**, 295.
- 10 M. I. Newton, F. Martin, K. Melzak, E. Gizeli and G. McHale, *Electron. Lett.*, 2001, **37**, 340.